



Banquette Seating

Southwest Upholstery are one of the leading bespoke banquette seating manufacturers in the UK, offering custom-made banquette seating for restaurants, pubs, clubs, and kitchens. Our banquette seating is made to order and comes in various styles and dimensions that can be customised to your specifications.



Why choose banquette seating?



*We believe
banquette seating
to be a practical
yet impressive
solution to elevate
your interiors
without having to
compromise on
space.*

*The proof is in the
pudding, our recent
projects showcase
the beauty of this
upholstery.*



“We are so pleased that we chose South West Upholstery. Right from the start they were so helpful, so honest and transparent with the way they guided us through material choice and design. The finished product installed at Flourish Foodhall & Kitchen was just amazing. The fitting team were great and made every effort. Thank you for an excellent job”

Paul Castle, Flourish



Choosing your banquette

Keep it simple at our set sizes or go that step further and design something unique



STANDARD OR BESPOKE

Our process is different to most as our seating is CNC-made! This means our way of working provides ease for our clients as we work off-site and deliver a ready-to-use, pre-made banquette so there's no faff on site!

Our frameworks are also able to be freestanding units due to their sturdiness, being made of 18mm Plywood and MDF.

Both the base and back cushioning are applied to MDF boards which can be removeable which means when it comes to repair work it's easy to uplift any areas which may have been damaged over the years!

From Plain finish to fluted or buttoned, there's something for everyone.



UPHOLSTERY FINISH

Banquette seating has an endless combination of styles. Once you've chosen your frame method there are many options for the upholstery finishes of buttons/fluting/plain. Then you can customise your seating in terms of colours, materials, kickplates or legs!

What's your preferred comfort?



COMFORT GRADE / SHAPE

We recommend our standard combination to get a high-quality finish that lasts the test of time in heavy usage areas however, if you're after something softer we have another combination to give you the finished seat that works for you and your space.

SEE NEXT PAGE FOR BESPOKE



Bespoke Items

If our set designs don't take your fancy we can work alongside you to create something bespoke and unique to you. Whether it's a domestic private project or working with designers on larger scale projects we are always happy to explore new ideas and see if we can help bring your vision to life.

We can have discussions surrounding the best option for design and functionality driven by our upholstery experts, to ensure you are getting the best product.

This bespoke option as expected incurs additional costs for the design process involved to create and manufacture something entirely bespoke. But it means it's the correct seating for you, created by us.



Noah's - Bristol



Cosy Club - Milton Keynes



Standard Banquette Styles

SIZES

With the help of our in-house design team, we can propose seating at our standard sizes which is customisable in a range of styles and endless choices of materials.

The following styles are all representative of our set standard sizing, our sizing is generous for a comfortable dining environment or even for more casual seating.

The sizes suit both domestic and commercial settings and can be amended if needed for a more bespoke piece.

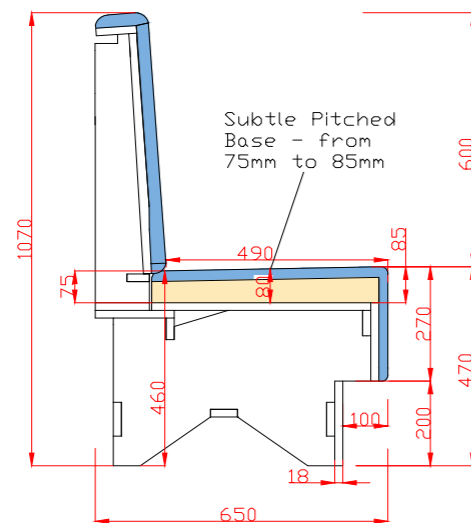

PLAIN



BUTTON BACK



FLUTED - INDIVIDUAL



FLUTED - STITCH

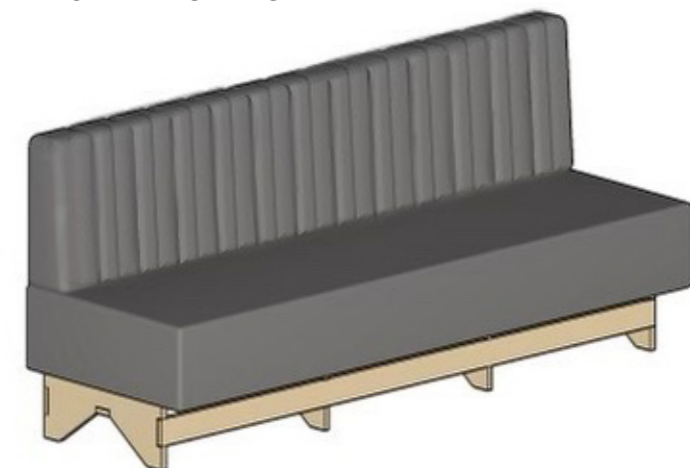

Standard Banquette Styles



1

PLAIN

SIMPLE & TIMELESS

You cannot go wrong with this one, whether you're working with a loud interior space or just prefer something simple. This look works great and represents the less is more approach!

2

FLUTED - INDIVIDUAL

SLEEK & MODERN

A popular choice to give your seating that extra something. Flutes can look smart in a range of environments.

Tip: It also looks great when contrasting fabrics between base and back flutes!



3

FLUTED - STITCH

UNDERSTATED & NEAT

Flutes made with the stitch method can be a lovely simple touch to give the banquette an extra something and add a touch of elegance.

4

BUTTON BACK

CLASSIC & ELEVATING

Button back finish is a lovely look and is a great way to show off the upholstery. It takes a plain fabric and creates a beautiful finish.



Kickplate Options

Kickplates are a great way to finish your banquette/booths, available as standard from our range as oak or matt black. However, if you'd prefer an alternative colour we can supply MDF to size that you can paint to whatever colour you fancy.



MFC BONDED WITH EGGER -H3170
NATURAL KENDAL OAK ST12

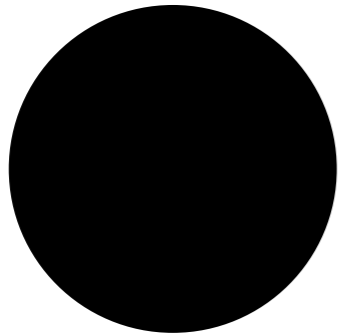

MFC BONDED WITH EGGER
-U999 BLACK ST2



RAW MDF BOARD - WITH OTHER
TO PAINT

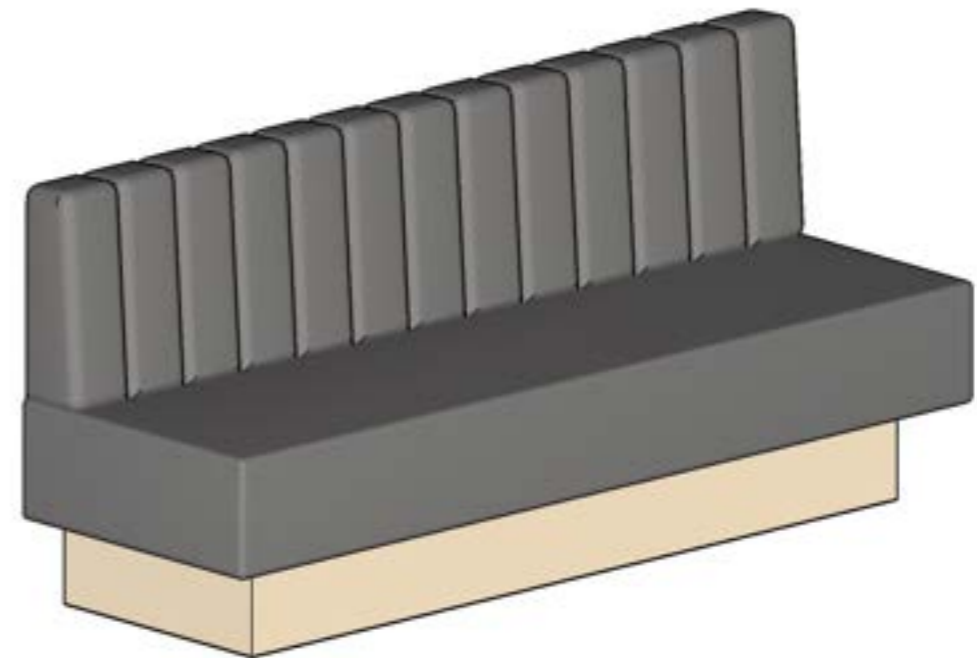

Leg Options



ROUND WOODEN LEG
- NATURAL FINISH
OR RAW FINISH WITH
OTHER TO STAIN



TAPERED LEG -
NATURAL FINISH OR
RAW FINISH WITH
OTHER TO STAIN



Foam options

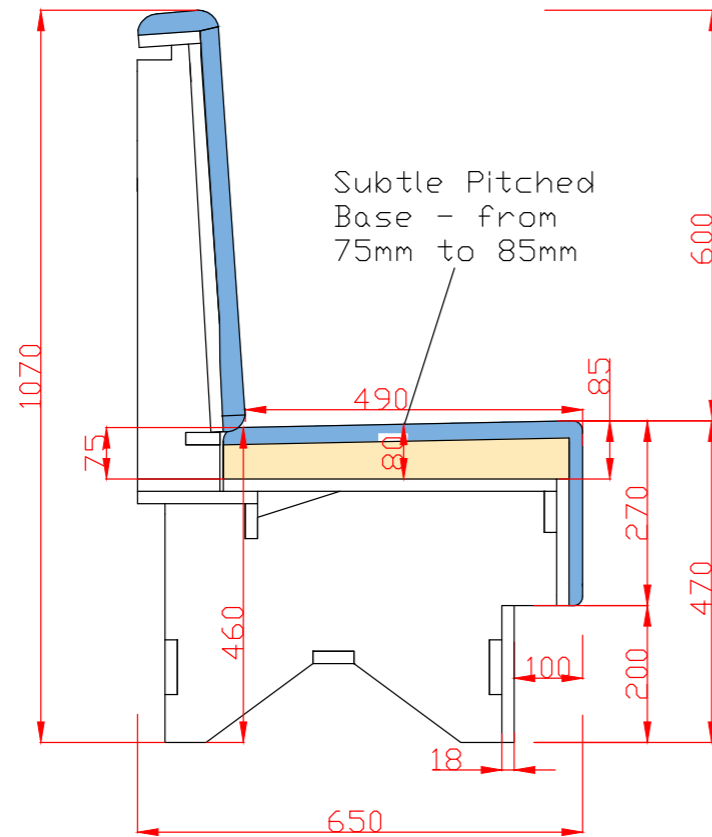

STANDARD FOAMS

Our favoured combination - this involves having a slight pitch in the base foam which gives a more deluxe feel to the shaping. This model is great for commercial and heavily used places, it's generous premium firm foam will give longevity to this item and make for a comfortable seating area.

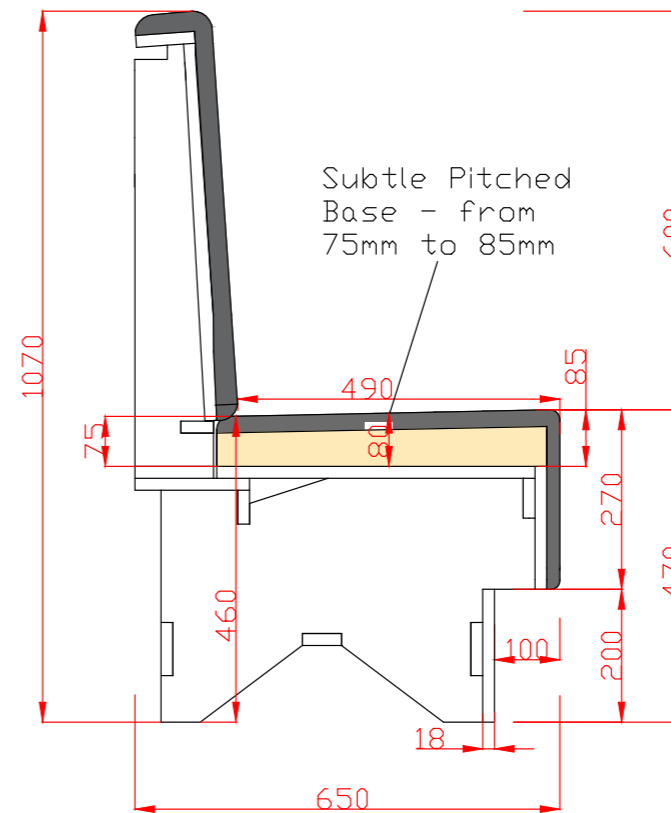

SOFTER BASE

Following on from our tried and tested shape, this foam combination allows for a softer feel and allows you to sink into the seat and relax. This embodies more of a 'sofa style' feel and works perfectly in casual areas.



Delivery & Installation



FINISHING TOUCHES...

Here at Southwest Upholstery, we are set apart from others as we ensure your item is handled with care from start to finish. With our in-house delivery team and designated vehicles, we can make the delivery process easy and carefree for you.

Whilst most banquette seating is made in situ our CNC and upholstery process means that we can rock up on the day, quickly get it in place, make a few adjustments if needed to kickplates and before you know it you'll be enjoying your new luxurious pre-made seating.



Case Study: Cosy Club

1 OF 2

PROJECT :

Cosy Club

LOCATION :

Milton Keynes

WHEN :

October 2022



FABRIC :

Pattern Fabric - Vittoria Flame Velvet by Anna Hayman Designs

Plain Fabric - Brick Plush by Warwick Fabric

WHAT :

The upholstered fluted wall panel design and 'U' shaped booths are just one of the many areas that we upholstered and fitted for this project! We've done this booth design twice now for them and it is a great style to have, especially as it is easy to assemble for fitting and even for future reupholstery if any sections need attention. We love how the patterned and plain velvets work together and compliment the fluted design. The seating is finished with brass to match the surrounding this scheme and add a touch of elegance

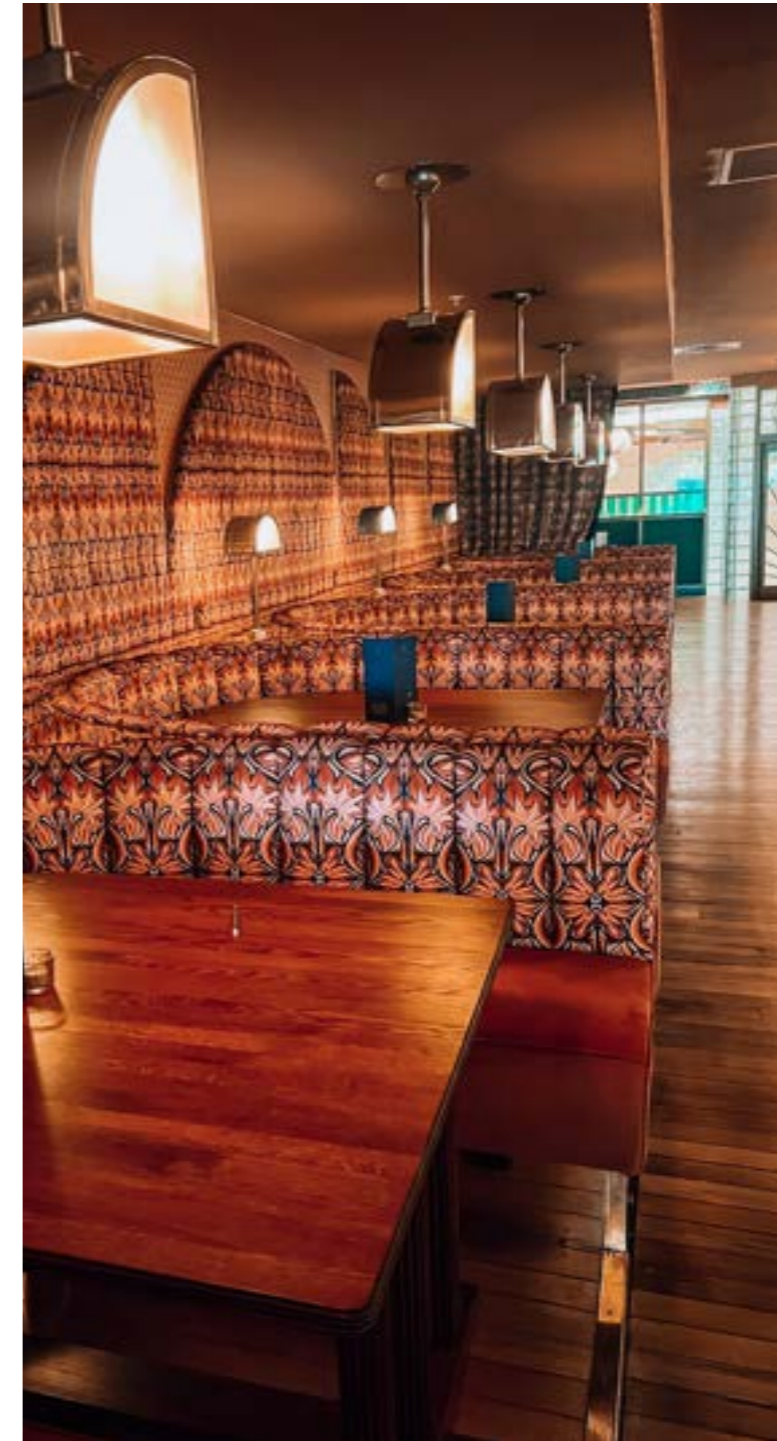

Case Study: Cosy Club

2 0 F 2

Seating, Stunning fabrics, and Shiny brass made for the perfect combination on this project.

The designers behind the stunning interiors of Cosy Club are always known to push boundaries. We worked alongside their design team to take initial sketch ideas and produce CAD modelling that runs directly through to our CNC systems to produce bespoke frameworks that we apply upholstery and other finished touches such as brass.

just like our clients we love to push boundaries too and we loved seeing the stunning outcome of this wonderful seating run.



DRAWING TO FOLLOW FROM OUR CLIENT

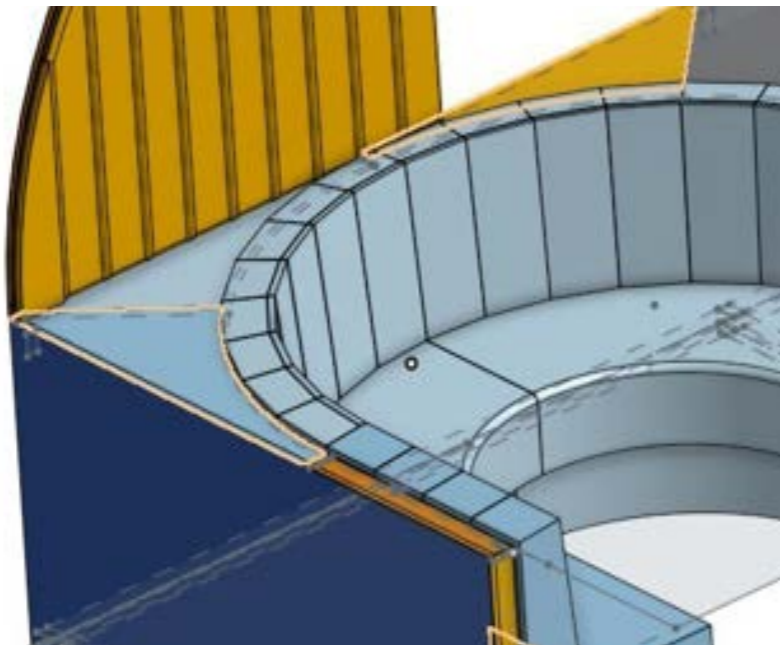

PRE - MANUFACTURE VISUAL



SWU - SITE INSTALL



Case Study: Imperial Sports Ground

P R O J E C T : Imperial Sports Ground (South West Sports Centre)

L O C A T I O N : Brislington, Bristol

W H E N : September 2021

M A T E R I A L : Faux Leather - Sunbury Torro



Craftworks Ltd contacted us about being involved in the refit at the South Bristol Sports Centre (now known as Imperial Sports Ground-). They required bespoke, custom-built bench seating in a variety of shapes and sizes. We were able to provide a quotation from the technical drawings provided, and once we were given the go-ahead used these drawings to create the seating.

Our frame makers and finishers made the banquette seating, while our team of talented upholsterers ensured an excellent finish on the seating in the bright colours our client had chosen. In addition, we upholstered dining chairs and stool bases to match the new colour scheme.

